



XTS-100K

Ku-Band Outdoor

Solid State Power Amplifiers

- 100 Watt
- No Shelter Required
- Short Waveguide Run
- Low Cost Installation
- Removable Power Supply
- Complete Digital M&C Interface
- Built-in Redundancy Control
 - 1:1
 - 1+1
 - 1:1 with load switching
- 3 Year Warranty



The XTS-100K high power solid state power amplifier is a compact, fully integrated antenna mount unit designed for low cost operation and longevity.

Intended for outdoor operation, the XTS-100K eliminates the need for a separate amplifier shelter. In addition, the distance between the amplifier and the antenna feed can be shorter, thus eliminating long waveguide runs and associated RF losses.

RF Filters, cooling, and monitor and control (M&C) systems are all self-contained within the package.

A high frequency resonant conversion power supply is used that accepts a wide range of prime power (90 to 264 VAC).

A remote external controller is available to operate the SSPA from a user-selected location.

Depending upon user requirements, these high power amplifiers can be configured for single thread, redundant, or phase combined configurations.

Mounting brackets are supplied to mount the high power amplifier to most popular antennas



Field Replaceable Power Supply

PERFORMANCE SPECIFICATIONS

Parameter	XTS-100K	
FREQUENCY RANGE standard other frequency coverage available	14 - 14.5 GHz	13.75 - 14.5 GHz (Option K2)
OUTPUT POWER		
Saturated Power (Typical)	50 dBm	49 dBm
Rated Power(P1dB) @ Amplifier Flange	49 dBm	48 dBm
GAIN		
Small Signal, minimum	60 dB, gain control set for maximum gain	
Small Signal, maximum	70 dB, gain control set for maximum gain	
Gain Flatness, maximum	2.0 dB	2.5 dB
Maximum SSG Variation Over:	0.6 dB per 80 MHz	
Slope, maximum	± 0.04 dB/MHz	
Stability, 24 Hr maximum	± 0.25 dB	
Stability, Temperature	± 2.0 dB maximum over temperature range at any frequency	
GAIN CONTROL	20 dB	
INTERMODULATION with two equal signals	- 25 dBc maximum with two equal carriers at 3 dB total power backoff from rated output	
HARMONIC OUTPUT, maximum	- 60 dBc	
AM/PM CONVERSION, maximum	2.5 deg/dB at 3 dB below rated output power	
NOISE POWER, maximum		
Transmit Band	- 80 dBW/4 kHz	
Receive Band	- 150 dBW/4 kHz 10.95 to 12.75 GHz	
GROUP DELAY, maximum		
Bandwidth	Any 80 MHz	
Linear	± 0.03 nS/MHz	
Parabolic	± 0.003 nS/MHz ²	
Ripple	1 nS/Pk-Pk	
RESIDUAL AM NOISE, maximum	- 50 dBc to 10 kHz - 20 (1.5 + logf) dBc 10 to 500 kHz - 85 dBc above 500 kHz	
PHASE NOISE, maximum	10 dB below IESS phase noise profile	
VSWR		
Input, maximum	1.2:1	
Output, maximum	1.3:1	

PRIME POWER

Working Range 90 MIN. - 264 MAX., VAC
47 to 63 Hz, single phase
1300 VA Typical
0.95 Minimum Prime Power Factor



OPTIONS

- Extended Frequency
13.75-14.5 GHz Option K2
- Redundancy Control
1:1 Option 29
1:1 w/load Switching Option 30
1+1 w/switches Option 31
- Built-in L-Band Block Upconverter Option B1
Frequencies Available:
14 - 14.5 GHz
13.75 - 14.5 GHz

ENVIRONMENT

NONOPERATING TEMPERATURE RANGE	-50° C to +70° C
OPERATING TEMPERATURE RANGE	-40° C to +50° C 2° C/1000 feet derating
HUMIDITY	Up to 100% Condensing
ALTITUDE	12,000 feet MSL maximum
SHOCK AND VIBRATION	Normal Transportation
COOLING	Forced Air

INTERFACE

TYPE		FUNCTION	
LOCAL CONTROL		Prime Power ON/OFF	Local/Remote
		Power Supply ON/OFF	Transmit ON/OFF
LOCAL STATUS		Tri-Color LED:	
		Fault: Red	Standby: Amber
		Transmit ON: Green	
REMOTE CONTROL		Transmit ON/OFF	RF Inhibit
		RF Attenuation	Fault Reset
		Summary Fault	Constant Power
REMOTE STATUS		Transmit ON	Transmit/Standby Hours
		RF Output Power	Fault Identification
		Reflected Power	Temperature
	Form C Dry Contact Closure	Summary Fault	
COMPUTER	Hardware Interface	2 ports: RS-232 & RS-422/485	
SERIAL PORT	Xicom Command Set	ASCII Commands	
RF MONITOR PORT		-40 dB Coupling Value (Nominal)	

XTS-100K High Power Solid State Amplifiers



Block Diagram

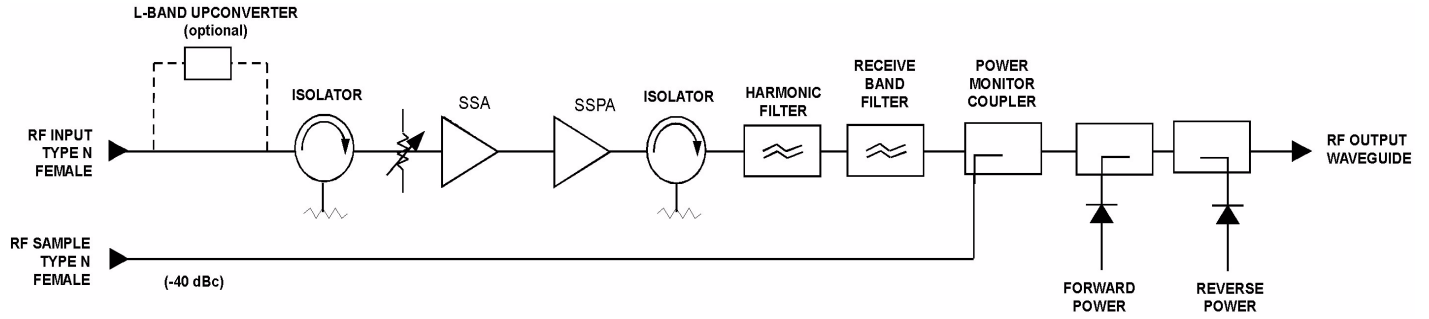

Outline Drawing

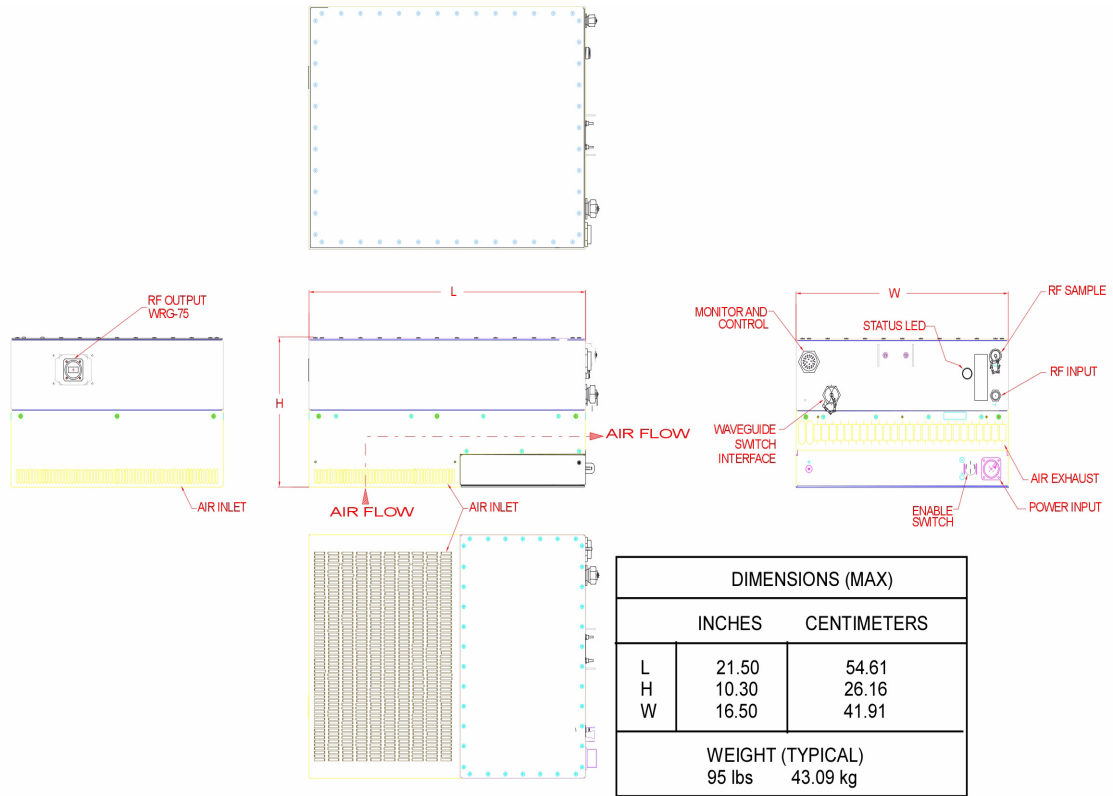

TYPICAL APPLICATIONS

1+1 COMBINED SYSTEMS

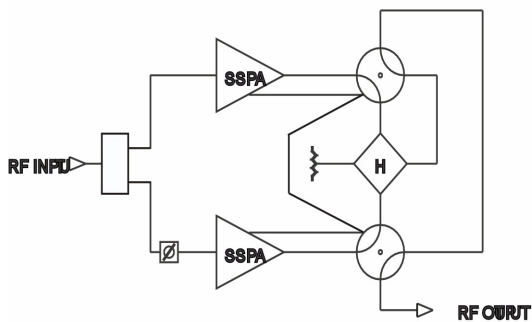

1:1 REDUNDANT SYSTEMS

