



XTD-400C/X/Ku-Band Antenna Mount Amplifiers



- 400 Watts C-Band
400 Watts X-Band
400 Watts Ku-Band
- No Shelter Required
- Short Waveguide Run
- Power Factor Corrected
- High Efficiency Dual-Stage TWTs
- Complete RS-232/422/485 Interface

The XTD-400 is a compact self contained antenna mountable power amplifier designed for low cost installation and long life. The XTD-400 design eliminates the need for an amplifier shelter as well as a long waveguide run between the amplifier and the antenna feed horn. RF filters, cooling, and monitoring & control (M&C) systems are all self contained within the High Power Amplifier (HPA). These features provide high reliability, low maintenance costs, and low replacement costs.

The XTD-400 uses high efficiency dual-stage collector Traveling Wave Tubes (TWT). Some benefits of this type of TWT are:

- Reduced prime power consumption
- Lower internal operating temperatures
- Reliability enhancement

These benefits are obtained for both the linear and saturated modes of operation. The XTD-400 incorporates power factor

correction circuitry which minimizes line current distortion and reduces the required volt-amps. The combination of power factor correction and high efficiency TWTs reduces input Volt-Amps by 45% when compared to equivalent amplifiers. A high frequency resonant conversion power supply is used that accepts a wide range of prime power (100 to 260 VAC). The automatic features of the power supply include quick recovery from prime power outages and multiple helix fault resets (three fault cycles).

A complete serial M&C system is built into the unit.

The XTD-400 may be configured for single thread, redundant, phase-combined, to linearized operation.

A remote external controller is available to operate the HPA from a user selected locations. Mounting brackets can be supplied to mount the HPA to most popular antennas.

PERFORMANCE SPECIFICATIONS

Parameter	XTD-400C, C-Band	XTD-400X, X-Band	XTD-400K, Ku-Band
FREQUENCY RANGE	5.850 to 6.425 GHz	7.90 to 8.40 GHz	13.75 to 14.5GHz
Extended Frequency Coverage	(5.85 to 6.725 GHz)		(12.75 to 14.50 GHz)
OUTPUT POWER			
Traveling Wave Tube	400 Watts	400 Watts	400 Watts
Rated Power @ Amplifier Flange	350 Watts	350 Watts	350 Watts
GAIN			
Large Signal, minimum	70 dB	70 dB	70 dB
Small Signal, minimum	75 dB	75 dB	75 dB
Attenuator Range (continuous)	25 dB	25 dB	25 dB
Maximum SSG Variation Over:			
Any Narrow Band	1.0 dB per 40 MHz	1.0 dB per 40 MHz	1.0 dB per 80 MHz
Full Band	2.5 dB	3.0 dB	2.5 dB
Slope, maximum	± 0.04 dB/MHz	± 0.04 dB/MHz	± 0.04 dB/MHz
Stability, 24 Hr maximum	± 0.25 dB	± 0.25 dB	± 0.25 dB
Stability, Temperature	± 1.0 dB maximum over temperature range at any frequency		
INTERMODULATION with two equal signals	- 18 dBc maximum with two equal carriers at 4 dB total power backoff from rated output		
HARMONIC OUTPUT, maximum	- 60 dBc	- 60 dBc	- 60 dBc
AM/PM CONVERSION, maximum	2.5 deg/dB at 3 dB below rated output power		
NOISE POWER, maximum			
Transmit Band	- 70 dBW/4 kHz	- 70 dBW/4 kHz	- 70 dBW/4 kHz
Receive Band	- 150 dBW/4 kHz 3.7 to 4.2 GHz	- 70 dBW/4 kHz 7.25 to 7.75 GHz	- 150 dBW/4 kHz 10.95 to 12.75 GHz
GROUP DELAY, maximum			
Bandwidth	Any 40 MHz	Any 40 MHz	Any 80 MHz
Linear	0.01 nS/MHz	0.01 nS/MHz	0.01 nS/MHz
Parabolic	0.005 nS/MHz ²	0.005 nS/MHz ²	0.005 nS/MHz ²
Ripple	0.5 nS/Pk-Pk	0.5 nS/Pk-Pk	0.5 nS/Pk-Pk
RESIDUAL AM NOISE, maximum	- 50 dBc to 10 kHz - 20 (1.5 + logf) dBc 10 to 500 kHz - 85 dBc above 500 kHz		
PHASE NOISE, maximum	10 dB below IESS phase noise profile AC fundamental -50 dBc Sum of all spurs -47 dBc		
VSWR			
Input, maximum	1.3:1	1.3:1	1.3:1
Output, maximum	1.3:1	1.3:1	1.3:1

PRIME POWER OPTIONS

100-260 VAC
47 to 63 Hz, single phase
1550 VA Maximum
0.95 Minimum Prime Power Factor

Remote External Controller
Extended Frequency Range (6.725 - 7.025 GHz)
1:1, 1:2, 1:N Redundancy
Variable Phase Combined
Integrated Linearizers



ENVIRONMENT

NONOPERATING TEMPERATURE RANGE	-50° C to + 70° C
OPERATING TEMPERATURE RANGE	-40° C to +50° C
HUMIDITY	Up to 100% Condensing
ALTITUDE	10,000 feet MSL maximum
SHOCK AND VIBRATION	Normal Transportation
COOLING	Forced Air

INTERFACE

TYPE	FUNCTION		
LOCAL CONTROL	Prime Power ON/OFF	Local/Remote	
	Power Supply ON/OFF	HV ON/OFF	
LOCAL STATUS	Tri-Color LED:		
	Fault: Red	Standby: Continuous Amber	
	HV ON: Green	FTD: Flashing Amber	
REMOTE CONTROL	HV ON/OFF	RF Inhibit (HV OFF)	Heater Standby
	RF Attenuation (w/preamp)	Fault Reset	
REMOTE STATUS	HV ON	Heater/Beam Hours	Filament Time Delay
	RF Output Power	Fault Identification	Helix Current
	Reflected Power	TWT Temperature	Helix Voltage
Form C Dry Contact Closure	Summary Fault		
RF MONITOR PORT	-37 dB Coupling Value (Approx)		

XTD-400C/X/Ku High Power Amplifiers



Block Diagram

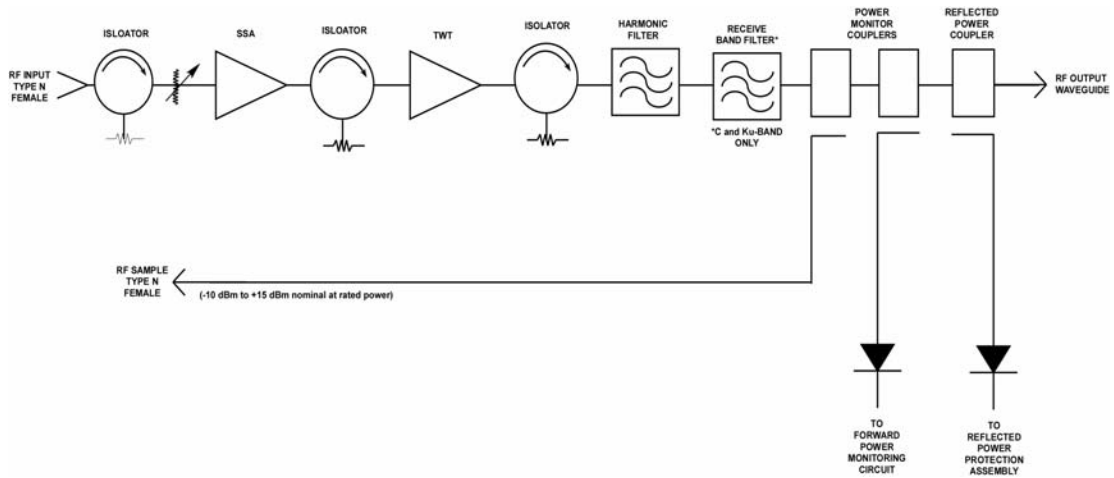

Outline Drawing

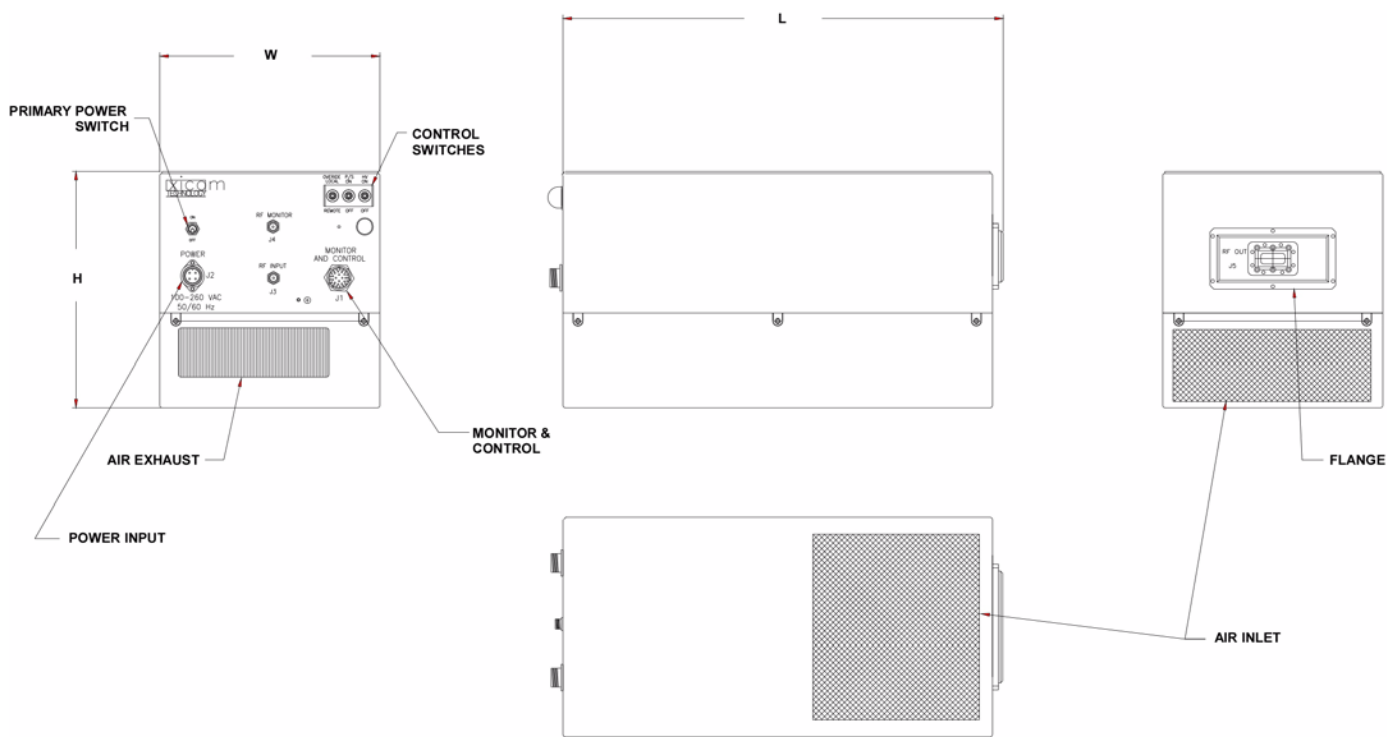

DIMENSIONS		
	INCHES	CENTIMETERS
W	10.25	26.04
L	20.50	52.07
H	11.0.0	27.94

Nominal Weight = 55 lbs. (24.95 kg)

RF OUTPUT

C-BAND - CPR 137G
X-BAND - CPR 112G
OR CPR 137G
Ku-BAND - WR 75



Document # 805-1109-001 11/02/2004
 XTD-400C/XKu REV 2
 © 2004
 Note: Technical specifications are subject to change without notice. Please contact Xicom Technology before using this information for system design.

3550 Bassett Street • Santa Clara, CA • 95054
 Tel: (408) 213-3000 • Fax: (408) 213-3001
 www.xicomtech.com