



XT-450TLW C, X, and Ku-Band Tri-Band Antenna Mount Amplifiers



- **325 Watts, C-Band
450 Watts, X-Band
325 Watts, Ku-Band**
- **No Shelter Required**
- **Short Waveguide Run**
- **Power Factor Corrected**
- **High Efficiency Dual-Stage
TWTs**

The XT-450TLW series are compact self-contained antenna mountable power amplifiers designed for low cost installation and long life. The XT-450TLW series design eliminates the need for an amplifier shelter as well as a long waveguide run between the amplifier and the antenna feed horn; for example, an antenna mounted 350 Watt amplifier with its shorter waveguide run will often deliver EIRP comparable to a 600 Watt rack mounted HPA. RF filters, cooling, and monitoring & control systems are all self-contained within the HPA. These features provide high reliability, low maintenance costs, and low replacement costs.

The XT-450TLW series incorporates high efficiency, dual-stage collector TWTs. Some of the benefits of this type of TWT are: reduced prime power consumption, lower internal operating temperatures, and reliability enhancement. These benefits are obtained for both the linear and saturated modes of operation. One of the features of the XT-450TLW series is incorporation of power factor correction circuitry

that minimizes line current distortion and reduces the required volt-amps. The combination of power factor correction and high efficiency TWTs reduces input Volt-Amps by 45% when compared to equivalent amplifiers. A high frequency resonant conversion power supply is used that accepts a wide range of prime power (100 to 260 VAC). The automatic features of the power supply include quick recovery from prime power outages and multiple helix fault resets (three fault cycles).

A complete monitoring & control system is built into the unit. Ten status and fault monitors are provided for external monitoring.

The XT-450TLW series can be configured for single thread, redundant, phase combined, or linearized operation.

A remote external controller is available to operate the HPA from a user selected location. Mounting brackets can be supplied to mount the HPA to most popular antennas.

PERFORMANCE SPECIFICATIONS

| Parameter | C-Band, XT-450TLW | X-Band XT-450TLW | Ku-Band, XT-450TLW |
|---|---|------------------------------------|--------------------------------------|
| FREQUENCY RANGE | 5.850 to 6.425 GHz | 7.90 to 8.40 GHz | 14.0 to 14.5 GHz |
| OUTPUT POWER | | | |
| Traveling Wave Tube | 325 W 55.1 dBm) | 450 W (56.5 dBm) | 325 W 55.1 dBm) |
| Rated Power @ Amplifier Flange | 290 W (54.6 dBm) | 400 W (56 dBm) | 290 W (54.6 dBm) |
| GAIN | | | |
| Large Signal, minimum | 65 dB | 65 dB | 65 dB |
| Small Signal, minimum | 70 dB | 70 dB | 70 dB |
| Maximum SSG Variation Over: | | | |
| Any Narrow Band | 1.0 dB 40 MHz | 1.0 dB 40 MHz | 1.0 dB 40 MHz |
| Full Band | 2.5 dB | 2.5 dB | 2.5 dB |
| Slope, maximum | ±0.04 dB/MHz | ±0.04 dB/MHz | ±0.04 dB/MHz |
| Stability, 24 Hr maximum | ± 0.25 dB | ± 0.25 dB | ± 0.25 dB |
| Stability, Temperature | ± 1.0 dB maximum over temperature range at any frequency | | |
| INTERMODULATION with two equal signals | -18 dBc maximum with two equal carriers at 4 dB total output backoff | | |
| HARMONIC OUTPUT, maximum | 0 dBc @ 49 dBm | -10 dBc | -12 dBc |
| AM/PM CONVERSION, maximum | 2.5 deg/dB at 6 dB below rated power | | |
| NOISE POWER, maximum | | | |
| Transmit Band | - 64 dBW/4 kHz | - 64 dBW/4 kHz | - 64 dBW/4 kHz |
| Receive Band | - 64 dBW/4 kHz 3.7 to 4.2 GHz | - 64 dBW/4 kHz 7.25 to 7.75 GHz | - 64 dBW/4 kHz 10.95 to 12.75 GHz |
| GROUP DELAY, maximum | | | |
| Bandwidth | Any 40 MHz | - 64 dBW/4 kHz | Any 80 MHz |
| Linear | 0.01 nS/MHz | | 0.01 nS/MHz |
| Parabolic | 0.005 nS/MHz ² | - 64 dBW/4 kHz | 0.005 nS/MHz ² |
| Ripple | 0.5 nS/Pk-Pk | 3.7 to 4.2 GHz | 0.5 nS/Pk-Pk |
| RESIDUAL AM NOISE, maximum | - 50 dBc to 10 kHz - 20 (1.5 + logf) dBc 10 to 500 kHz - 85 dBc above 500 kHz | | |
| PHASE NOISE, maximum | 10 dB below IESS phase noise profile AC fundamental -50 dBc Sum of all spurs -47 dBc | | |
| VSWR | | | |
| Input, maximum | 1.3:1 | 1.3:1 | 1.3:1 |
| Output, maximum | 2.2:1 | 2.2:1 | 2.2:1 |

PRIME POWER

100-260 VAC
47 to 63 Hz, single phase
2200 VA Maximum
0.95 Minimum Prime Power Factor

OPTIONS

Detected RF
Remote External Controller
Discrete Interface
Extended Frequency Coverage
1:1, 1:2, 1:N Redundancy



ENVIRONMENT

| | |
|--------------------------------|-------------------------|
| NONOPERATING TEMPERATURE RANGE | -50° C to + 70° C |
| OPERATING TEMPERATURE RANGE | -40° C to +50° C |
| HUMIDITY | Up to 100% Condensing |
| ALTITUDE | 10,000 feet MSL maximum |
| SHOCK AND VIBRATION | Normal Transportation |
| COOLING | Forced Air |

INTERFACE

| TYPE | FUNCTION | | |
|---|-------------------------|------------------------------|----------------------|
| CONTROLS | HV ON | Heater Standby | Fault Reset |
| | Power ON | | |
| <i>Note: Heater Standby reduces the TWT heater voltage for situations where the high voltage is off for extended periods.</i> | | | |
| MONITORS - DIGITAL | High Voltage ON | Heater Time Out (FTD) | Standby |
| | Helix Current/Arc Fault | Helix Current Latched Fault | Fan Fault |
| | Summary Fault | High Voltage Fault | |
| MONITORS - ANALOG | Helix Current (2 mA/V) | Cathode Voltage (1000:1 V/V) | +15 VDC (100 MA max) |
| | TWT Temperature | RF Output Power (optional) | +24 VDC (100 MA max) |

XT-450TLW Tri-Band High Power Amplifiers



Block Diagram

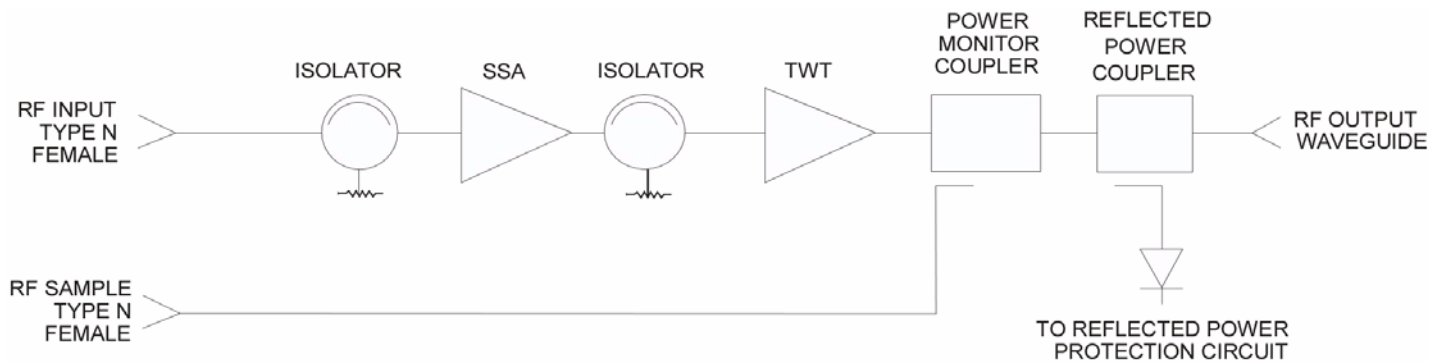

Outline Drawing

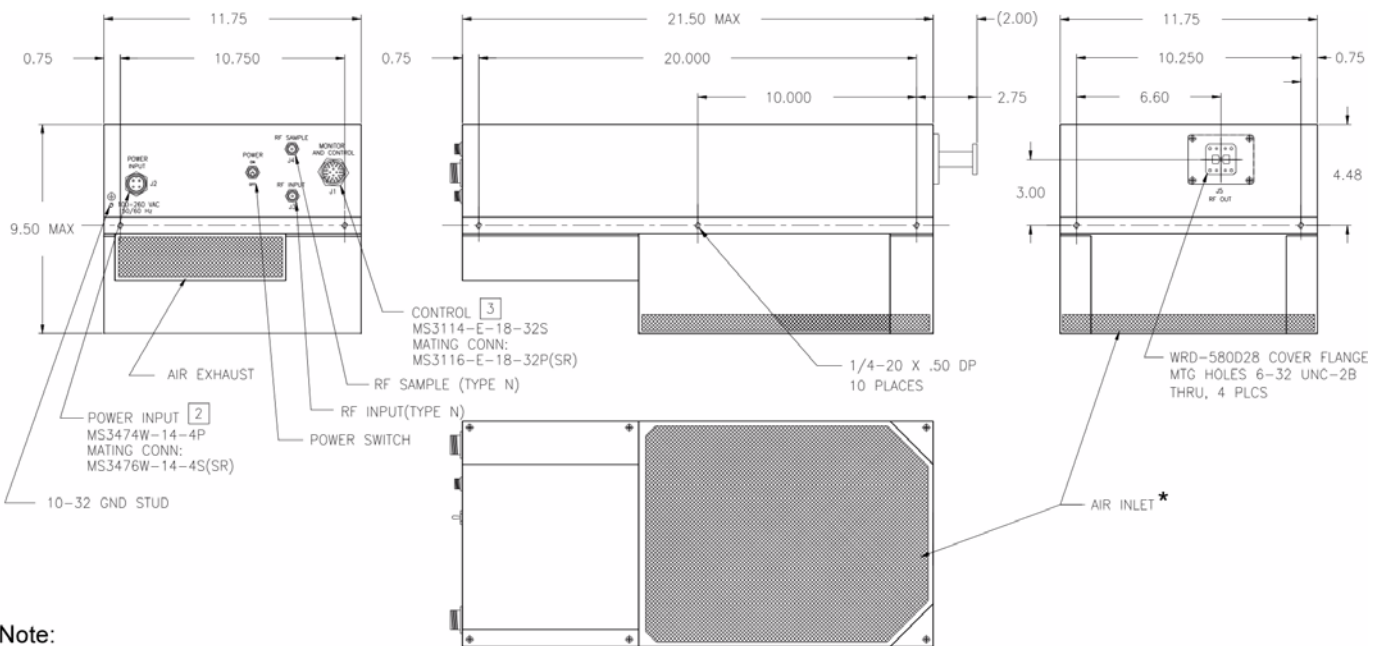

Note:
Mounting Brackets Not Shown
* requires Air Flow Clearance

Typical Weight: 56 lbs (25.4 kg)