

# OmniPole

## 2 GHz Central Receive Antenna



### Applications

- Omni-directional antenna for central receive systems

### Features

- High Gain: 11 dBi
- Omnidirectional
- Choice of models:
  - 1.7 to 1.99 GHz
  - 1.99 to 2.2 GHz
  - 2.2 to 2.5 GHz
- No remote switching required
- Rugged design
- Low wind resistance
- Simple installation
- LNA/Filter option
- Mounting hardware included
- Optional 8 dBi model

### Overview

The OmniPole is a vertically polarized central receive, omnidirectional system which provides 360 degree coverage with 11 dBi of gain. Other gains with greater elevation beamwidth are also available. Standard OmniPole models cover 1.7 to 1.99, 1.99 to 2.2, or 2.2 to 2.5 GHz.

An optional LNA is available and is powered through the RF cable. The OmniPole is designed to be side mounted on a tower or other suitable structure. The OmniPole can also be used as an omnidirectional transmit antenna.

# SPECIFICATIONS

## GENERAL

Frequency Band, choice of: 1.7 to 1.99, 1.99 to 2.2, or 2.2 to 2.5 GHz  
 Antenna Gain: .....13 dBi min.  
 Azimuth Beamwidth: .....360°  
 Elevation Beamwidth: .....6°  
 Polarization: .....Vertical  
 LNA/Filter: .....Optional  
 Gain: .....26 dB  
 LNA Noise Figure: .....2 dB typ., 2.5 dB max  
 Power Requirements (Note): .....+15 to +28 Vdc @ 70 mA  
 Filter Bandwidth: .....Approx. 200 MHz  
 Connector: .....Type "N" Female

## PHYSICAL CHARACTERISTICS

Size: .....58" long x 3-1/2" diameter (147 x 8.9 cm)  
 Weight: .....Approximately 5 lbs (2.3 kg)  
 (not including mounting brackets)  
 Mounting: .....Hardware supplied to attach to  
 3.5" to 4.5" (8.9 to 11.4 cm) diameter pipe

*Note: The Omnipole LNA is powered through the interconnecting coax. Some receivers, such as the earlier model MRC receivers, provide a DC output on the receiver for this purpose. If DC is not available, then a suitable low current 18 to 24 Vdc power supply is required. A bias "T" (P/N 900371) should be connected in series with the RF coax cable at the receiver in order to inject the DC onto the coax cable. This bias "T" is provided with the Omnipole/LNA unit.*

## CONFIGURATIONS

High Gain Omnidirectional Antennas

### OMNIPOLE 11 DBI (MOUNTS TO 2" TO 4.5" POLES)

- 11 dBi, vertical, no LNA, 1.7 to 1.9 GHz
- \*11 dBi, vertical, 24 dB gain LNA, PCS/MMDS filter and bias "T," 1.99 to 2.11 GHz
- \*11 dBi, vertical, 12 dB gain LNA, PCS/MMDS filter and bias "T," 1.99 to 2.11 GHz
- 11 dBi, vertical, no LNA, 1.99 to 2.11 GHz
- \*11 dBi, vertical, 24 dB gain LNA, PCS/MMDS filter and bias "T," 2.3 to 2.5 GHz
- \*11 dBi, vertical, 12 dB gain LNA, PCS/MMDS filter and bias "T," 2.3 to 2.5 GHz
- 11 dBi, vertical, no LNA, 2.3 to 2.5 GHz

### OMNIPOLE 8 DB (MOUNTS TO 2" TO 4.5" POLES)

- 8 dBi, vertical, no LNA, 1.7 to 1.9 GHz
- \*8 v, vertical, 24 dB gain LNA, PCS/MMDS filter and bias "T," 1.99 to 2.11 GHz
- \*8 dBi, vertical, 12 dB gain LNA, PCS/MMDS filter and bias "T," 1.99 to 2.11 GHz
- 8 dBi, vertical, no LNA, 1.99 to 2.11 GHz
- \*8 dBi, vertical, 24 dB gain LNA, PCS/MMDS filter and bias "T," 2.3 to 2.5 GHz
- \*8 dBi, vertical, 12 dB gain LNA, PCS/MMDS filter and bias "T," 2.3 to 2.5 GHz
- 8 dBi, vertical, no LNA, 2.3 to 2.5 GHz
- \*Power supply rack, required

## MOUNTING KIT FOR OMNIPOLE

Mounting hardware kit, Omnipole

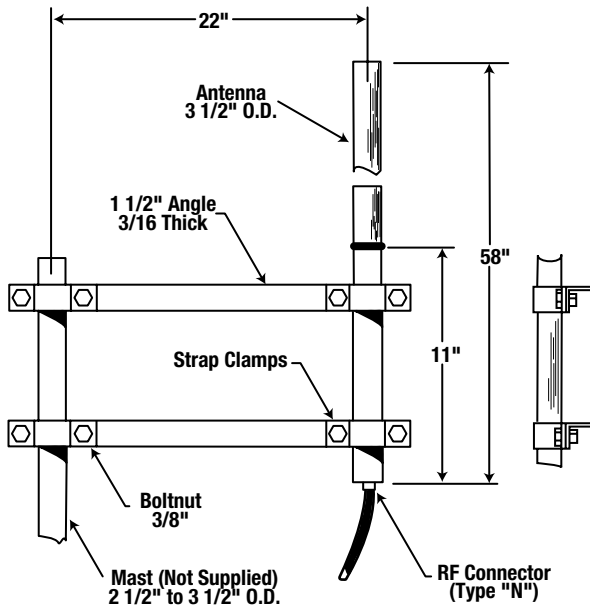

Omnipole Antenna Mounting Diagram



Microwave Radio Communications  
 101 Billerica Avenue, Building #6  
 North Billerica, MA USA  
 01862-1256

Tel: +1.978.671.5700  
 Fax: +1.978.671.5800  
 e-mail: info@mrcbroadcast.com  
 web site: www.mrcbroadcast.com

MRC products are manufactured under a quality system certified to ISO 9001. MRC reserves the right to make changes to specifications of products described in this data sheet at any time without notice and without obligation to notify any person of such changes.

© November 2002 Microwave Radio Communications (Part N° 60081)

